

# FORD PERFORMANCE



January 17, 2025

## Technical Service Bulletin – 28

### Fuel Cell Fittings – Fuel Cell Pump Out

Purpose: To allow for a closed system fuel pump out process with the addition of a Staubli quick disconnect fitting assembly. Applies to vehicles 1-40.

Fuel Cell Cover Plate With Fittings Installed



Vehicle With Pump Out System



The update requires the following parts and the drilling of one hole in the fuel cell cover plate.

## New parts

### Staubli Fitting

- Staubli Quick Disconnect & Nut SPT08.5655/L/JKV
- McMaster-Carr Washer 95606A560

### Cover Plate Modification

Drill 19 mm through holes at the defined locations if adding both a Staubli and a dash 8 AN bulkhead fitting (Optional).

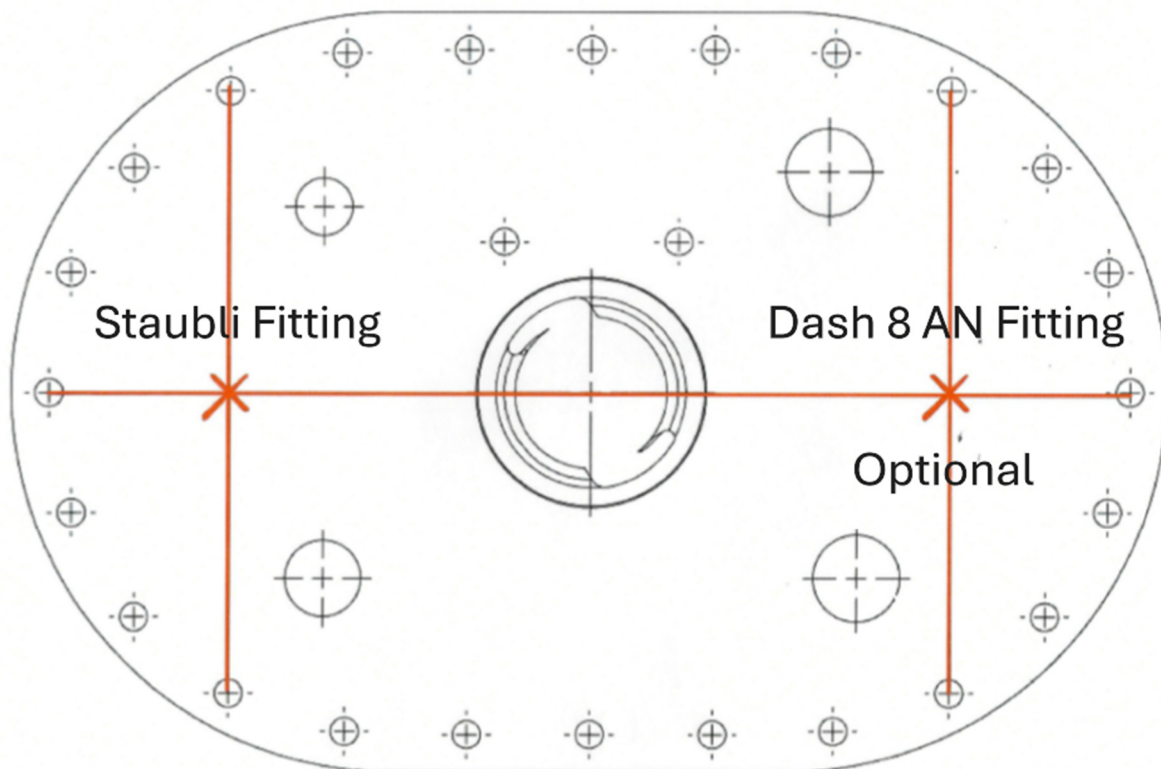

## Staubli Pump Out Fitting Return Assembly



There is an option to add a second hole for a dash 8 AN bulkhead fitting if needed for any other pump out or fueling use.

### New Parts

#### Optional Dash 8 AN Bulkhead Fitting

- ATL Dash 8 AN Bulkhead Fitting & Nut TF232
- ATL Dash 8 AN Cap AN929-8D
- McMaster-Carr Washer 95606A560

#### Dash 8 AN Bulkhead Fitting Assembly

